

5MT

# WBM

WILD BOAR MODELS

## WBM-014 GWR CORDON

The Great Western Railway build many 'Cordon' gas tank wagons on reclaimed carriage underframes, these wagons were used to transport gas to stations that didn't have a mains gas supply.

The gas was then used for platform and coach lighting etc. Some of these wagons lasted until the 1960's however most had been withdrawn before.

The kit requires assembly and features NEM coupling pockets that will accept compatible couplings. 14mm Disc wheels are required along with paints and transfers and couplings. Bearings are optional as it runs fine without them, however the axle boxes need opening out further to take bearings.

Due to the printing process used to manufacture this product there may be a rough finish to this model, 2 coats of spray primer and some sanding should suitably smoothen the surface.

Prior to painting and assembly the spacers between the layers need removing these are marked in yellow in the diagram, take care when removing these from both sides.

Once spacers are removed, then paint as required before joining all 3 sections together UHU glue is a suitable adhesive for this task. Check alignment of parts before the glue sets.

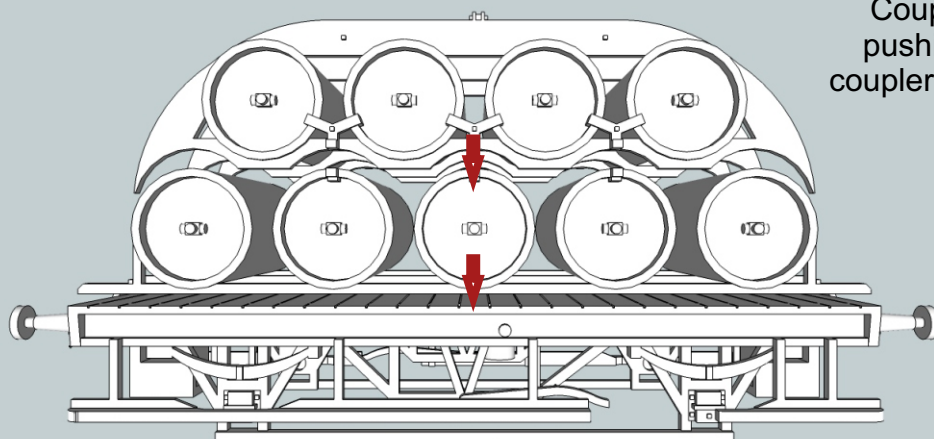
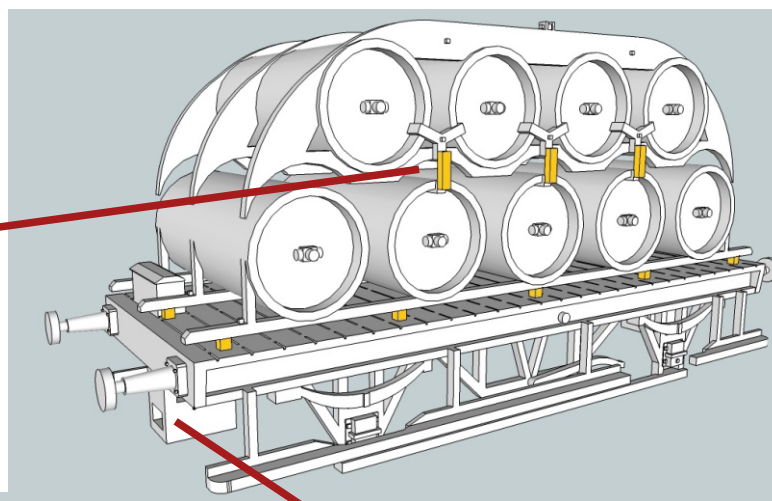

Coupling can be added by pushing them into the NEM coupler pockets provided on the wagons chassis.

Painting suggestions,

Frames and buffers: Humbrol 33 Matt Black  
Tanks and deck: Dark Grey

However for total accuracy we recommend using images of your chosen prototype.

Wild Boar Models hope you enjoy building this kit, if you want any more information about our kits please contact us at [www.wildboarmodels.co.uk](http://www.wildboarmodels.co.uk), also if you have any suggestions or recommendation we would gratefully receive your feedback.