

5MT

# WBM

WILD BOAR MODELS

## WBM-001 WARWELL WW2

A 00 gauge representation of the 1942-3 built warwell wagons used for moving tanks between military depots around the country. Though built for WW2 use, these lasted in service in a similar condition until the mid 1970's when they were rebuilt. These wagons usually ran in rakes with a ramp wagon marshalled at either end. This kit requires Ratio (125) Diamond frame bogies, as well as painting, transfers and couplings. These wagons are ideal for a first super detailing project such as fitting handbrake wheels, rivets and other finer details, without the added complexity of constructing the wagon body.

Due to the printing process used to manufacture this product there may be a rough finish to this model, 2 coats of spray primer and some sanding should suitably smoothen the surface.

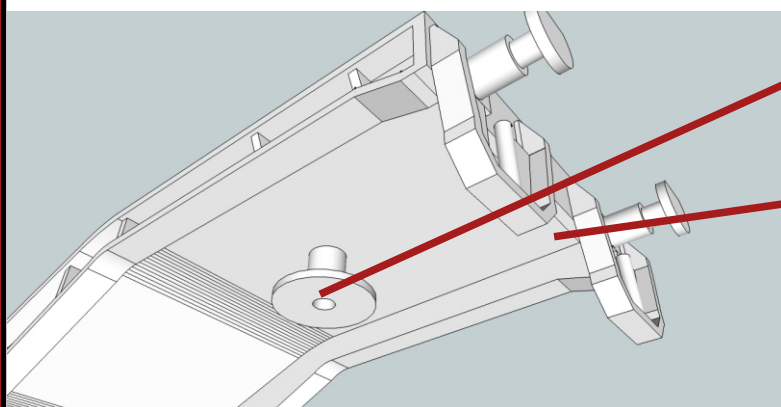
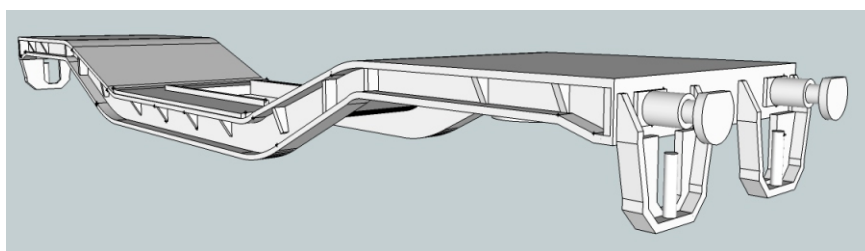

When adding the bogies it may be necessary to carefully open out the pivot to accept the mounting pin. If you wish to add tension lock couplings, remove these from the bogies and add a small block behind the bufferbeam to allow this to sit on.



Painting suggestions,

Bogies and buffers: Humbrol 33 Matt Black

Frames: Phoenix Precision P76 S.R. Maunsell Light Olive (Dull)

Deck: Suitable shades of brown for wooden planking

However for total accuracy we recommend using images of your chosen prototype.

Wild Boar Models hope you enjoy building this kit, if you want any more information about our kits please contact us at [www.wildboarmodels.co.uk](http://www.wildboarmodels.co.uk), also if you have any suggestions or recommendation we would gratefully receive your feedback.